

Multiple Spring Seal

Materials

Rotary - Car / SiC / SSiC / TC
 Elastomer - NBR / EPDM / Viton / Aflas / FFKM

Working Conditions

Pressure ≤ 30 bar
 Speed ≤ 30 m/s
 Temperature up to 205°C

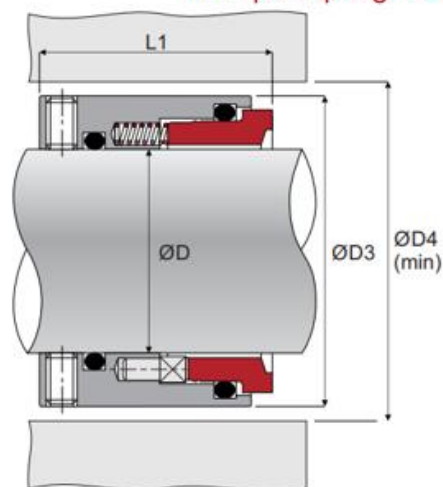

Shaft ØD		ØD3		ØD4 (min)		L1	
Inches	Metric	Inch	mm	Inch	mm	Inch	mm
0.625	16	1.181	30	1.339	34	1.252	31.8
-	18	-	32	-	34	-	31.8
0.750	20	1.339	34	1.417	36	1.252	31.8
0.875	22	1.417	36	1.496	38	1.252	31.8
-	24	-	38	-	40	-	31.8
-	25	-	39	-	41	-	31.8
1.000	28	1.654	42	1.732	44	1.272	32.3
1.125	30	1.732	44	1.811	46	1.272	32.3
1.250	32	1.811	46	1.89	48	1.272	32.3
-	33	-	47	-	49	-	32.3
1.375	35	1.929	49	2.008	51	1.272	32.3
1.500	-	2.047	52	2.205	56	1.311	33.3
-	38	-	53	-	56	-	33.3
-	40	-	55	-	58	-	33.3
1.625	-	2.244	57	2.402	61	1.311	33.3
-	43	-	58	-	61	-	33.3
1.750	-	2.323	59	2.48	63	1.311	33.3
-	45	-	60	-	63	-	33.3
1.875	-	2.441	62	2.598	66	1.311	33.3
-	48	-	63	-	66	-	33.3
-	50	-	66	-	69	-	33.8
2.000	-	2.677	68	2.835	72	1.331	33.8
-	53	-	69	-	72	-	33.8
2.125	-	2.756	70	2.913	74	1.331	33.8
-	55	-	71	-	74	-	33.8
-	58	-	76	-	80	-	38.8
-	60	-	78	-	82	-	38.8
2.250	-	3.071	78	3.346	85	1.528	38.8
2.375	63	3.189	81	3.346	85	1.528	38.8
2.500	65	3.268	83	3.425	87	1.528	38.8
2.625	70	3.465	88	3.622	92	1.748	44.4
2.750	-	3.465	88	3.622	92	1.748	44.4
2.875	75	3.661	93	3.819	97	1.748	44.4
3.000	-	3.661	93	3.819	97	1.72	43.7
3.125	80	4.055	103	4.213	107	1.72	43.7
3.250	85	4.252	108	4.409	112	1.72	43.7
3.375	-	4.252	108	4.409	112	1.917	48.7
3.500	90	4.449	113	4.606	117	1.917	48.7
3.625	95	4.646	118	4.803	122	1.917	48.7
3.750	-	4.646	118	4.803	122	1.917	48.7
3.875	100	4.843	123	5.000	127	1.917	48.7
4.000	-	4.921	125	4.693	119	1.917	48.7